

SR8

2 Phase Step Motor Drive



User Manual

Rev. 1.1

AMP & MOONS' Automation

Contents

1	Introduction.....	3
1.1	Overview.....	3
1.2	Features.....	3
1.3	Block diagram.....	4
2	Mounting the Drive	4
3	Connections	5
3.1	Connecting to the Power Supply	5
3.2	Connecting to a Motor	5
3.3	Connecting to the Inputs.....	6
3.3.1	Step & Direction Inputs.....	6
3.3.2	EN Input.....	7
3.3.3	Fault Output.....	8
4	Switch Selection	9
4.1	Running Current	9
4.2	Idle Current.....	9
4.3	Microstepping	9
4.4	Self Test.....	10
5	Motor Selection	10
5.1	Recommended Motors	11
6	Error Codes	13
7	Reference Materials	13
7.1	Mechanical Outline	13
7.2	Specifications.....	14
7.2.1	Electrical Specifications.....	14
7.2.2	Environmental Specifications	14
7.3	Torque Curves	15
8	Contacting MOONS'	16

1 Introduction

Thank you for selecting the MOONS' SR8 Motor Drive. We hope our commitment to performance, quality and economy will make a successful motion control project.

1.1 Overview

The SR series drives are cost-effective, high performance 2 phase step drives. The design is based on PID current control technology, and features high torque, low noise, and low vibration. The running current and microstep resolution are switch selectable.

1.2 Features

- Power Supply - operates from a 24 to 75 volt DC power supply
- Output Power - position switch selectable, 8 settings, maximum 7.8 amps peak
- Current Control - advanced digital current control provides excellent high speed torque
- Microstep Resolution - position switch selectable, 8 settings: 400, 800, 1600, 3200, 6400, 12800, 25600, 51200 step/rev
- Speed Range - speeds up to 3000 rpm
- Anti Resonance - raises the system-damping ratio to eliminate midrange instability and allow stable operation throughout the speed range of the motor.
- Auto Setup - measures motor parameters and configures motor current control and anti-resonance gain settings
- Microstep Emulation - performs high resolution stepping by synthesizing coarse steps into fine micro-steps
- Control Modes - Step & Direction or CW/CCW pulse
- Input Digital Filters - 2 MHz digital filter for high speed inputs
- Motor Type Select - a 16 bit rotary switch is used to select the desired motor database which is pre-loaded at the Factory
- Load Inertia Select - as part of the motor database each motor can be selected for use with low or high load inertia.
- Idle Current - switch selectable for 50% or 90% idle running current reduction 1 second after the motor stops
- Self Test - switch selectable, the drive will perform a 2 rev, 1 rps, CW/CCW move test

1.3 Block diagram

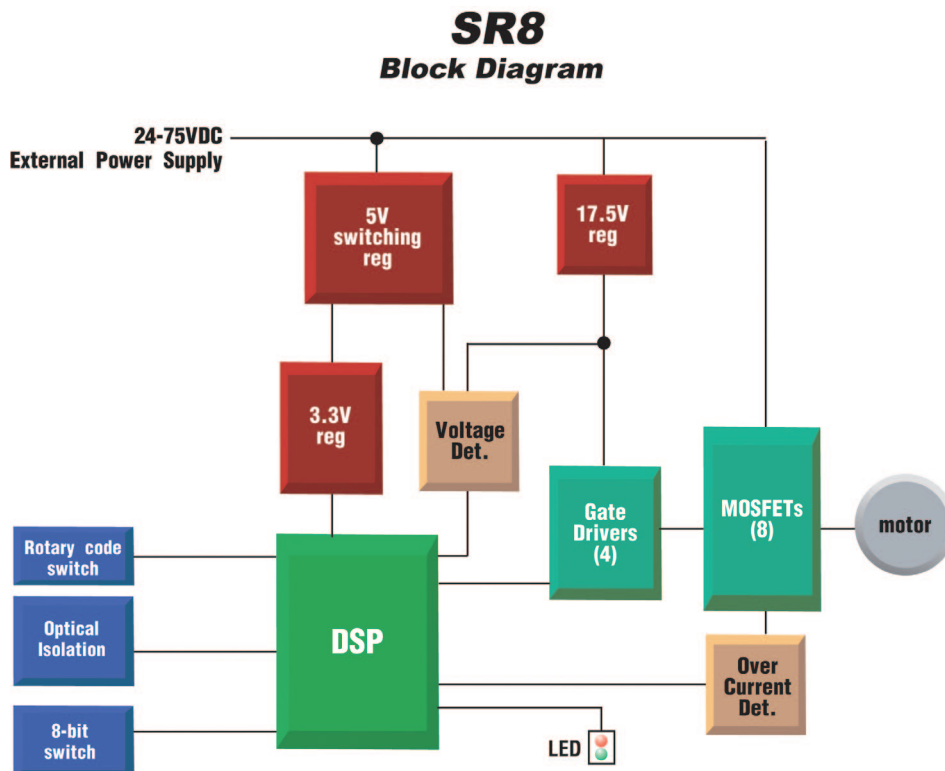

2 Mounting the Drive

The SR8 Step Drive can be mounted on the wide or the narrow side of the chassis. If it is mounted on the wide side, M3 screws should be used through the four corner holes. For narrow side mounting applications, M3 screws can be used in the two side holes.

The amplifiers in the drive generate heat. To operate the drive continuously at maximum power forced air cooling, as from a fan, should be provided.

Never use the drive in a space where there is no air flow or where other devices can cause the surrounding air to be more than 40 °C. Never put the drive where it can get wet or where metal particles can fall into it.

3 Connections

To use the SR8 Step Drive, the following items are needed:

- A power supply (24 - 75 VDC)
- Pulse & Direction signal
- A compatible step motor

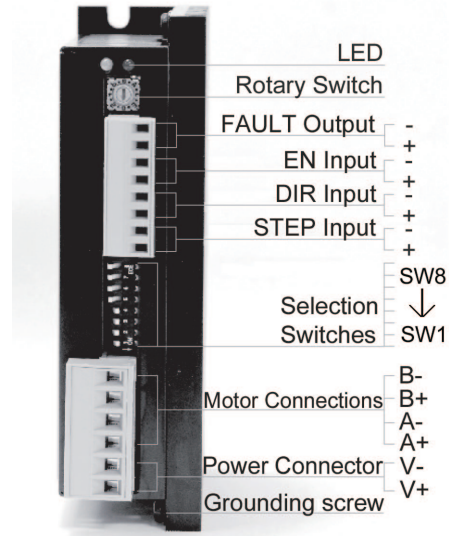

3.1 Connecting to the Power Supply

If the power supply does not have a fuse on the output or some kind of short circuit current limiting device, a fast acting fuse is required. An 8 amp fast acting fuse should be installed in line with the “+” power supply lead.

Connect the motor power supply “+” terminal to the drive terminal labeled “V+”. Connect the power supply “-” to the drive terminal labeled “V-”.

Be careful not to reverse the wires.

3.2 Connecting to a Motor

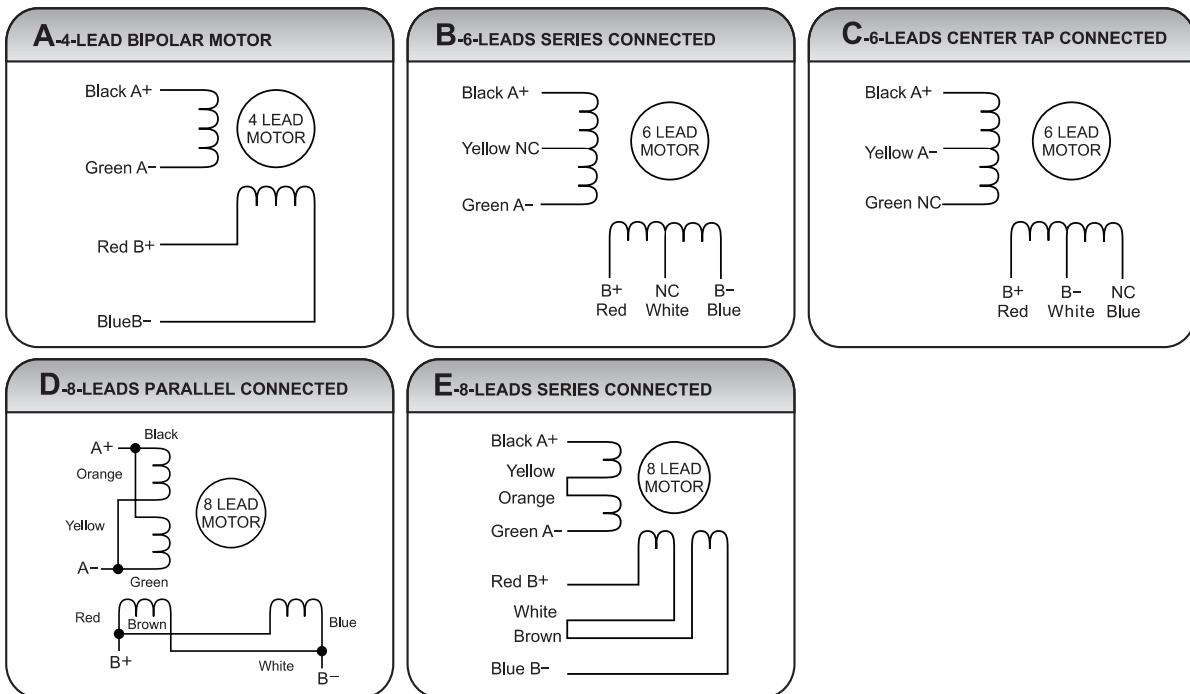

3.3 Connecting to the Inputs

3.3.1 Step & Direction Inputs

The SR8 Step Drive has two high speed optically isolated inputs called STEP and DIR. They accept 5 to 24 volt single-ended or differential signals, up to 2MHz. The maximum voltage that can be applied to the input is 28V.

The motor executes one step with the falling edge of the STEP signal.

The direction of rotation is controlled by the DIR signal level. A low level signal (0 level) will result in clockwise rotation, and a high level signal (1 level) will result in counterclockwise rotation.

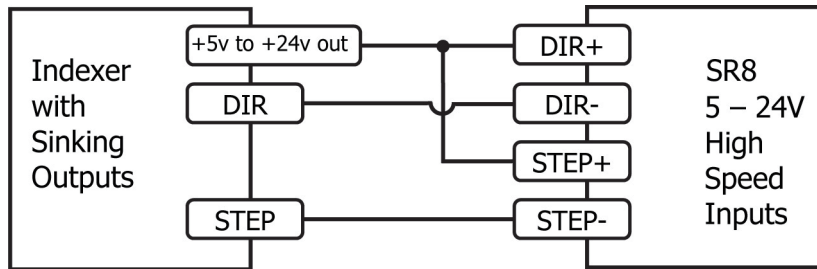

Connecting to Indexer with Sinking Outputs

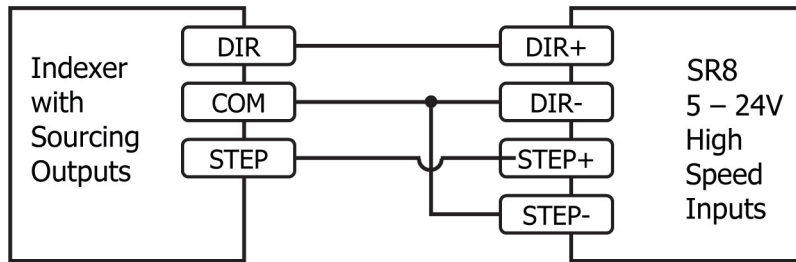

Connecting to Indexer with Sourcing Outputs

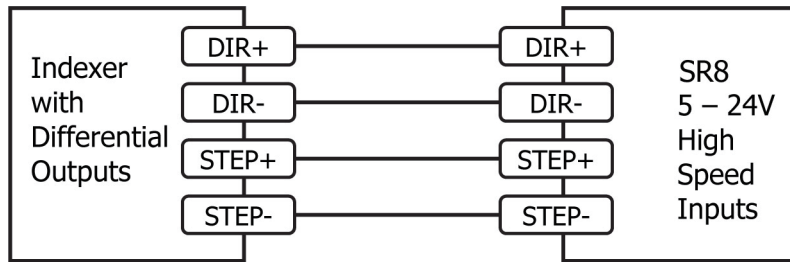

Connecting to Indexer with Differential Outputs
Many high-speed indexers have differential outputs

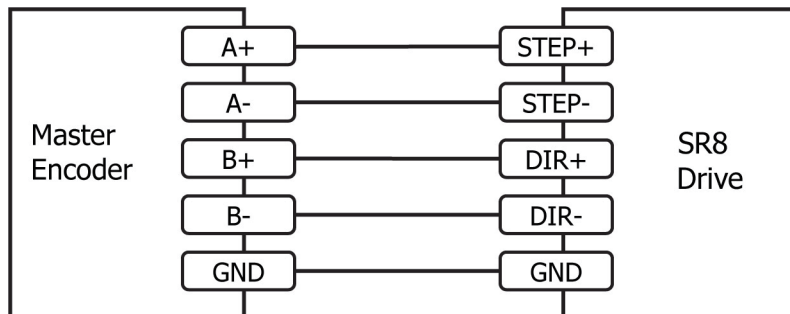

Wiring for Encoder Following

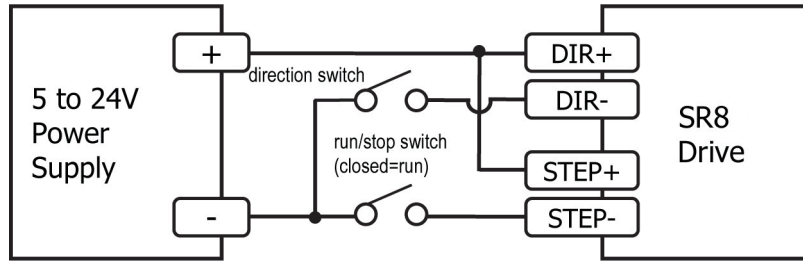

Using Mechanical Switches

3.3.2 EN Input

The EN input enables or disables the drive amplifier. It is an optically isolated input that accepts a 5 to 24 volt single-ended or differential signal. The maximum voltage that can be applied to the input is 28V.

When EN input is closed, the driver amplifier is deactivated. All the MOSFETs will shut down, and the motor will be free. When EN input is open, the drive is activated.

When the drive has encountered an error and the fault is removed from system, a falling signal into the EN input will reset the error status and activate the drive amplifier again.

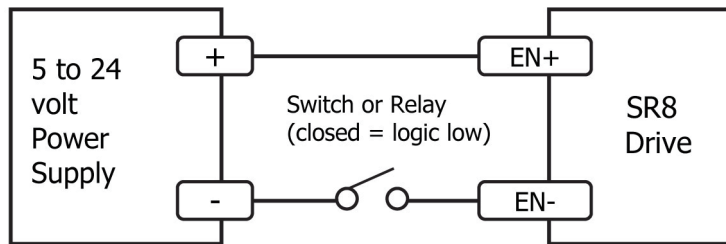

Connecting the Input to a Switch or Relay

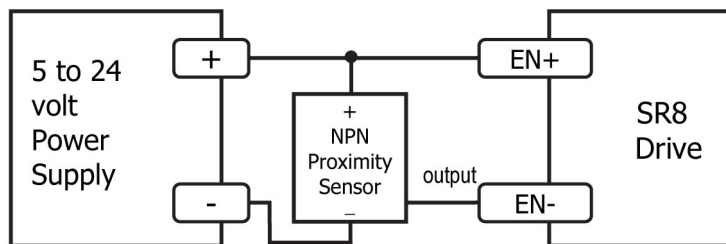

Connecting an NPN type Proximity Sensor to an input
(when prox sensor activates, input goes low)

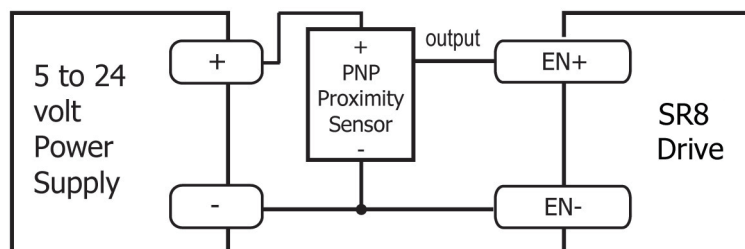

Connecting an PNP type Proximity Sensor to an input
(when prox sensor activates, input goes low)

3.3.3 Fault Output

The FAULT Output is optically isolated. The maximum collector current is 100mA, and the maximum collector to emitter voltage is 30 volts. The output can be wired to sink or source current.

When drive is working normally, the output is open. When the drive encounters an error, the output closes.

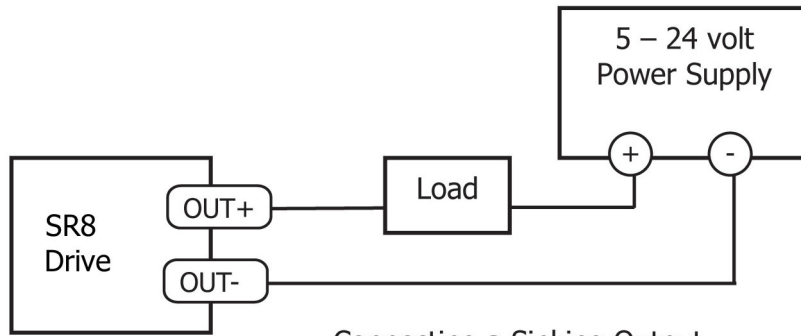

Connecting a Sinking Output

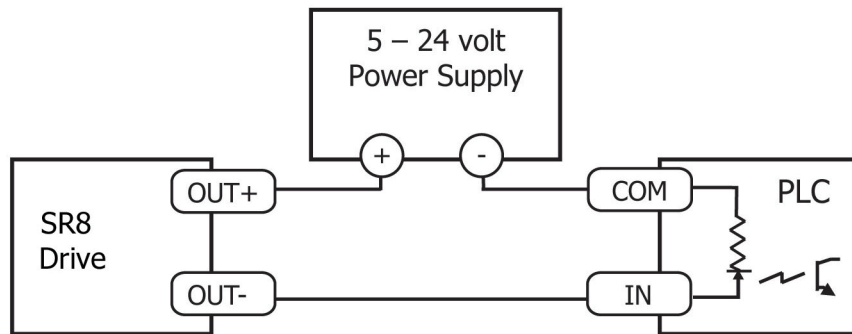

Connecting a Sourcing Output

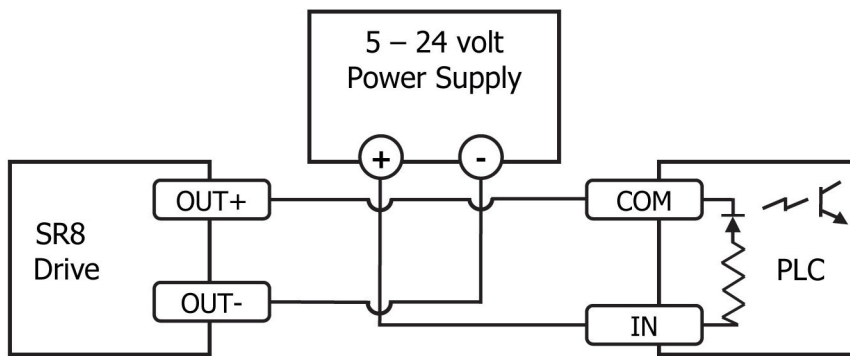

Connecting a Sourcing Output again

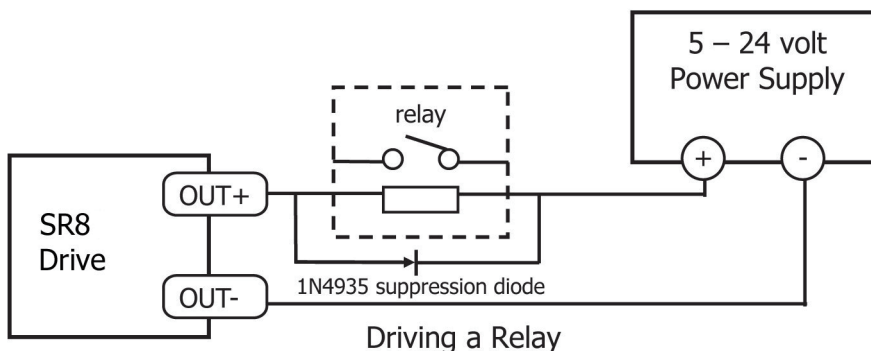

Driving a Relay

4 Switch Selection

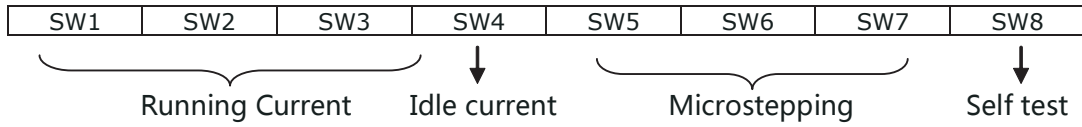

4.1 Running Current

The output current of the SR8 Step Drive is set by the SW1, SW2, and SW3 switches and can be changed as necessary. There are 8 settings available according to the ON/OFF combination of the switches.

Peak	SW1	SW2	SW3
2.4A	ON	ON	ON
3.2A	OFF	ON	ON
4A	ON	OFF	ON
4.8A	OFF	OFF	ON
5.6A	ON	ON	OFF
6.4A	OFF	ON	OFF
7A	ON	OFF	OFF
7.8A	OFF	OFF	OFF

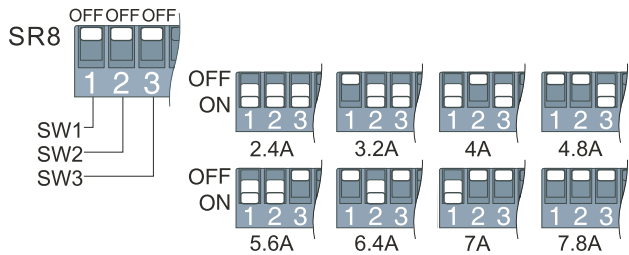

4.2 Idle Current

The running current of the SR8 drive is automatically reduced anytime the motor isn't moving. Setting the SW4 switch to ON reduces the current to 50% of its running value. Setting this switch to OFF maintains 90% of the running current. This 90% setting is useful when a high holding torque is required. To minimize motor and drive heating it is highly recommended that the idle current reduction feature be set to 50% unless the application requires the higher setting.

4.3 Microstepping

The microstep resolution is set by the SW5, SW6 and SW7 switches. There are 8 settings.

Microstep(step/rev)	SW5	SW6	SW7
400	ON	ON	ON
800	OFF	ON	ON
1600	ON	OFF	ON
3200	OFF	OFF	ON
6400	ON	ON	OFF
12800	OFF	ON	OFF
25600	ON	OFF	OFF
51200	OFF	OFF	OFF

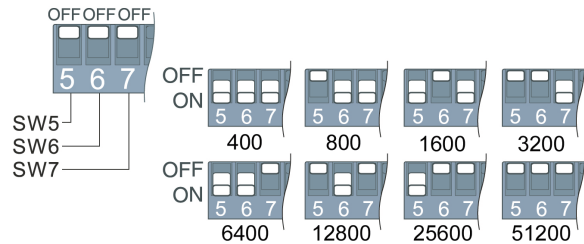

4.4 Self Test

Setting switch SW8 to ON after the drive is powered up will cause the drive to perform a self test move of 2 revolutions both CW and CCW at 1rps. Setting switch SW8 to OFF disables this feature.

5 Motor Selection

Each position of the 16-bit rotary switch selects a different motor, and automatically sets the configuration parameters in the drive. The SR8 drive comes programmed with up to 8 typical motors as factory defaults. Drives can be customized with specially selected motors when required.

The rotary switch also selects a low or high inertia for each motor to allow for various load conditions. The low setting is 1:1, and the high setting is 10:1. Each motor in the loaded database has unique settings to optimize the anti-resonance. See the table below.

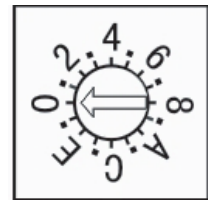

When the motor selection is changed, the drive power supply will need to be cycled.

Switch Setting	Motor
0	23HS0-L / AM23HS04B0-L*1
1	23HS2-L / AM23HS84B0-L
2	23HS3-L / AM23HSA4B0-L
3	24HS2-L
4	24HS5-L
5	34HD0-L
6	34HD1-L
7	34HD2-L
8	23HS0-H / AM23HS04B0-H*2
9	23HS2-H / AM23HS84B0-H
A	23HS3-H / AM23HSA4B0-H
B	24HS2-H
C	24HS5-H
D	34HD0-H
E	34HD1-H
F	34HD2-H

Motor selections ending in L are for low inertia and those ending in H are for high inertia.

5.1 Recommended Motors

23HS Series 1.8°

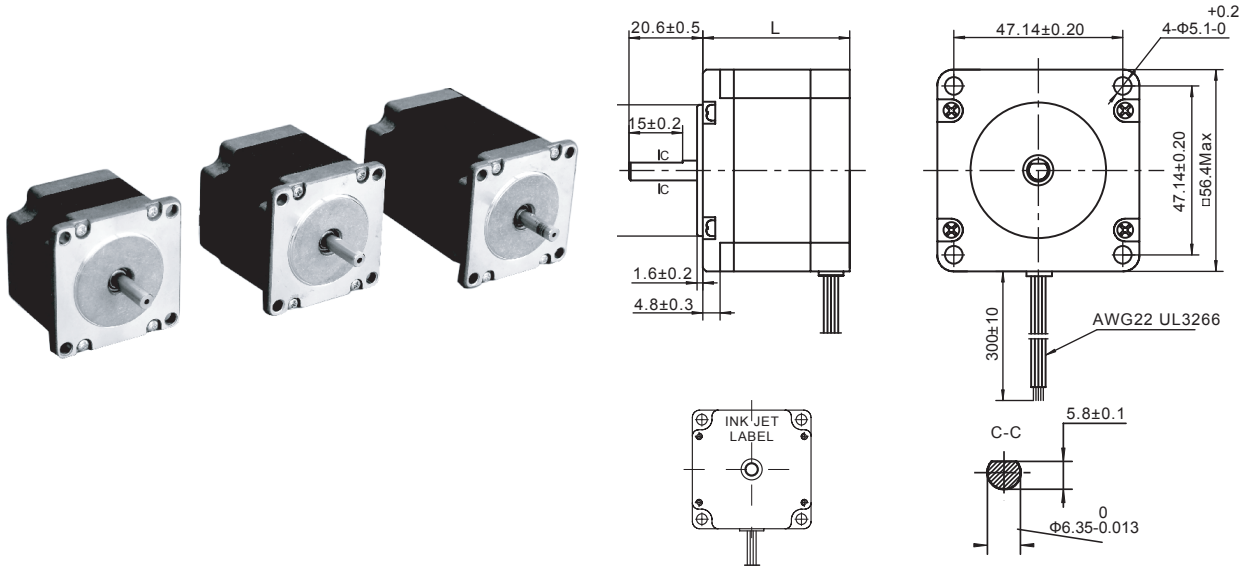

Unit: mm

Parameters

PART#	CONNECTION	MOTOR LENGTH (mm)	MOTOR HOLDING TORQUE (mNm)	#OF LEADS	STEP ANGLE (DEG)	AMPS	OHMS	MH	ROTOR INERTIA (G-CM ²)	MOTOR WEIGHT (Kg.)
23HS0416-01	bipolar	41	600	4	1.8	4.2	0.3	0.6	135	0.42
23HS2442-05	bipolar	54	1000	4	1.8	4.2	0.4	1.4	260	0.6
23HS3422-06	bipolar	76	1800	4	1.8	4.2	0.55	1.7	460	1

24HS Series 1.8°

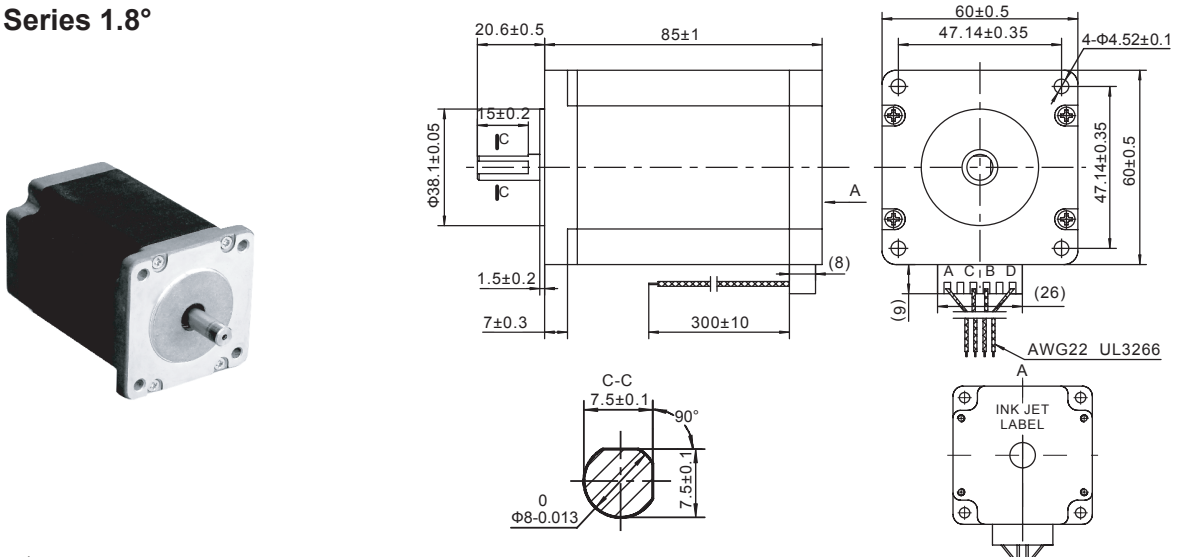

Unit: mm

Parameters

PART#	CONNECTION	MOTOR LENGTH (mm)	MOTOR HOLDING TORQUE (mNm)	#OF LEADS	STEP ANGLE (DEG)	AMPS	OHMS	MH	ROTOR INERTIA (G-CM ²)	MOTOR WEIGHT (Kg.)
24HS5401-10N	bipolar	85	2500	4	1.8	4.2	0.7	2.6	900	1.4

34HD Series 1.8°

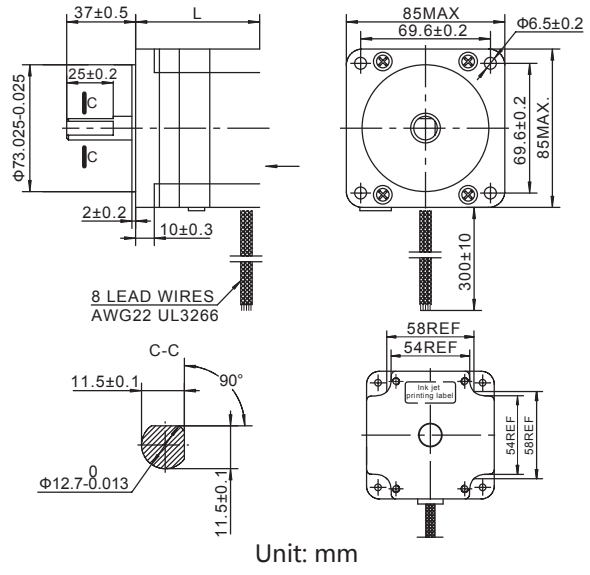
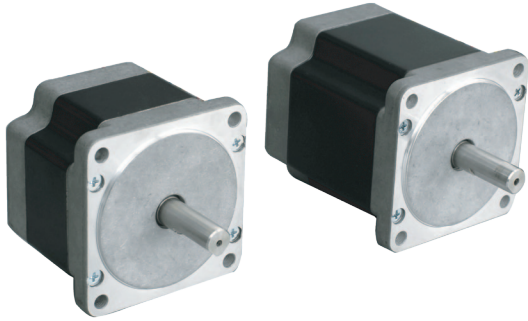

Parameters

PART#	CONNECTION	MOTOR LENGTH (mm)	MOTOR HOLDING TORQUE (mNm)	#OF LEADS	STEP ANGLE (DEG)	AMPS	OHMS	MH	ROTOR INERTIA (G-CM ²)	MOTOR WEIGHT (Kg.)
34HD0801-02	unipolar	66.5	2400	8	1.8	4.5	0.48	1.7	1100	1.6
	Bipolar series		3000			3.18	0.96	6.8		
	Bipolar parallel		3000			6.3	0.24	1.7		
34HD1801-02	unipolar	96	4800	8	1.8	4.5	0.66	2.7	1850	2.7
	Bipolar series		6500			3.18	1.32	10.8		
	Bipolar parallel		6500			6.3	0.33	2.7		
34HD2801-05	unipolar	125.5	7000	8	1.8	4	0.97	5.4	2750	3.8
	Bipolar series		9800			2.8	1.94	21.6		
	Bipolar parallel		9800			5.6	0.485	5.4		

6 Error Codes

The SR8 Step Drive has one bicolor (red/green) LED to indicate status. When the motor is enabled, the green LED flashes slowly. When the green LED is solid, the motor is disabled. If the red LED flashes, an error has occurred. Errors are indicated by a combination of red and green flashes as follows:

●	Solid green	Motor disabled
●●	Flashing green	Motor enabled
●●●●●●	3 red, 2 green	Bad internal voltage
●●●●●●	4 red, 1 green	Over voltage
●●●●●●	4 red, 2 green	Under voltage
●●●●●●	5 red, 1 green	Over current/short circuit
●●●●●●	6 red, 1 green	Open motor winding

7 Reference Materials

7.1 Mechanical Outline

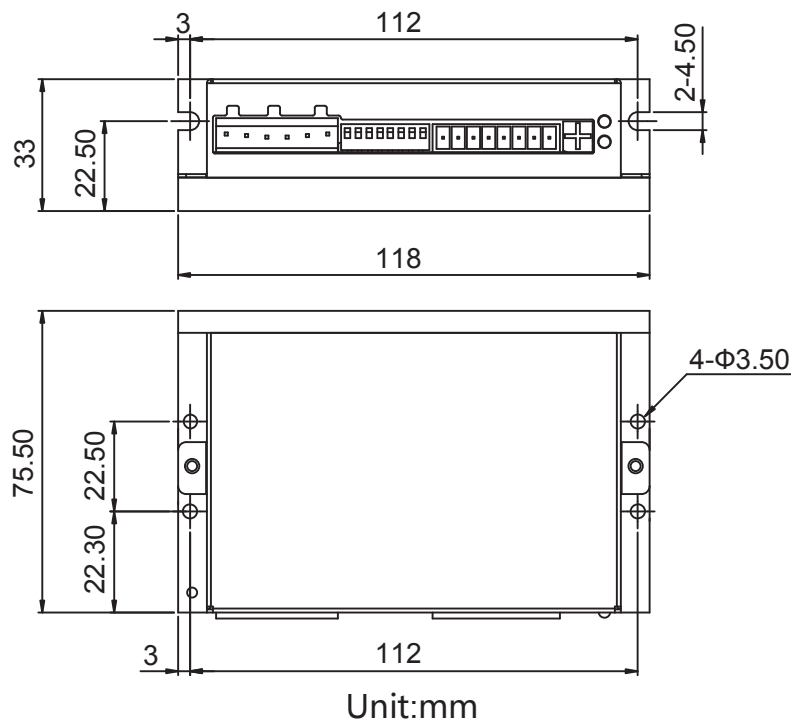

7.2 Specifications

7.2.1 Electrical Specifications

Parameter	Min.	Typ.	Max.	Unit
Power Supply	24	-	75	VDC
Output Current (Peak)	2.4	-	7.8	amps
STEP/DIR Input Signal Average Forward Current	6	10	15	mA
Step Frequency	2	-	2M	Hz
STEP Minimum Pulse Width Hi and Low	250	-	-	ns
DIR Minimum Pulse Width	50	-	-	us
Under Voltage Protection	-	20	-	VDC
Over Voltage Protection	-	85	-	VDC
STEP/DIR Input Signal Voltage	4.0	-	28	VDC
Driver Initialization time	-	-	2.5	S

7.2.2 Environmental Specifications

Heat Sinking Method	Natural cooling or fan-forced cooling
Surrounding Air Conditions	Avoid dust, oily mist and corrosive air
Operating Temperature	0 - 40°C (32 - 104°F)
Maximum Ambient Humidity	90% non-condensing
Shock	5.9m/s ² maximum
Storage Temperature	-10 - 70°C (14 - 158°F)

7.3 Torque Curves

23HS0416-01

Drive: SR8
Microstep: 51200 steps/rev
Current: 4.8A(Peak)

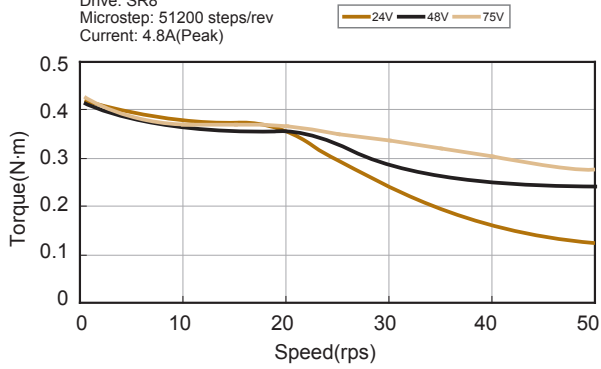

23HS2442-05

Drive: SR8
Microstep: 51200 steps/rev
Current: 4.8A(Peak)

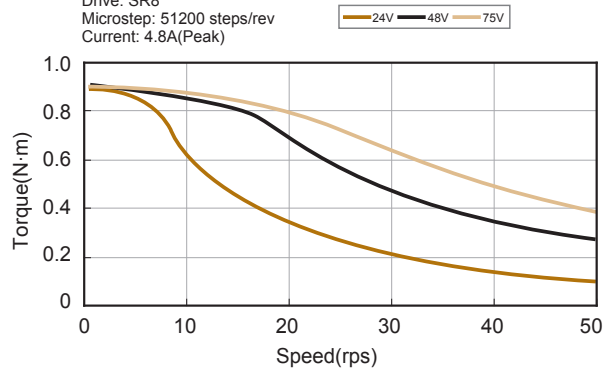

23HS3422-06

Drive: SR8
Microstep: 51200 steps/rev
Current: 4.8A(Peak)

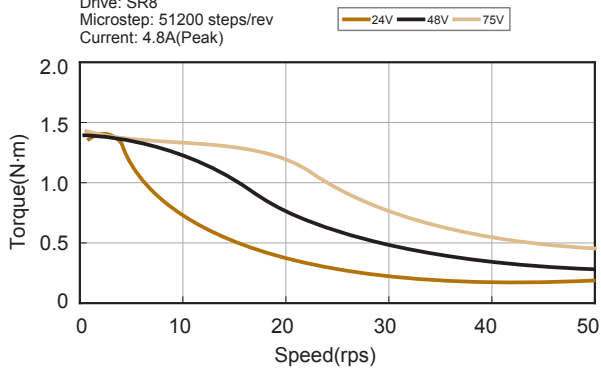

24HS5401-10N

Drive: SR8
Microstep: 51200 steps/rev
Current: 4.8A(Peak)

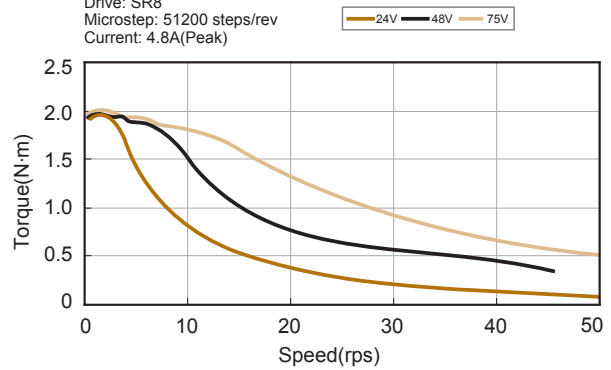

34HD0801-02

Drive: SR8
Microstep: 51200 steps/rev
Current: 6.4A(Peak)

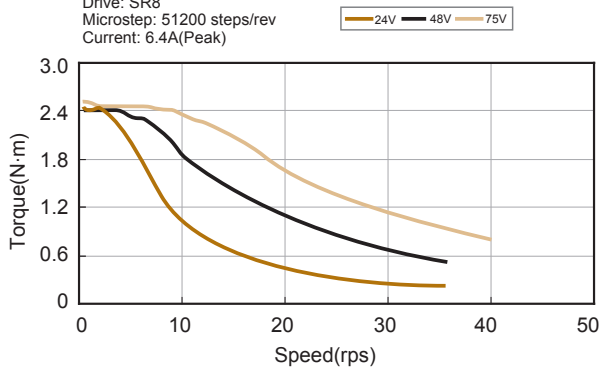

34HD1801-02

Drive: SR8
Microstep: 51200 steps/rev
Current: 6.4A(Peak)

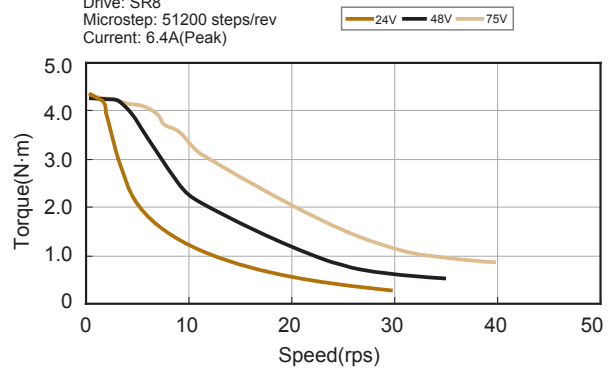

34HD2801-05

Drive: SR8
Microstep: 51200 steps/rev
Current: 5.6A(Peak)

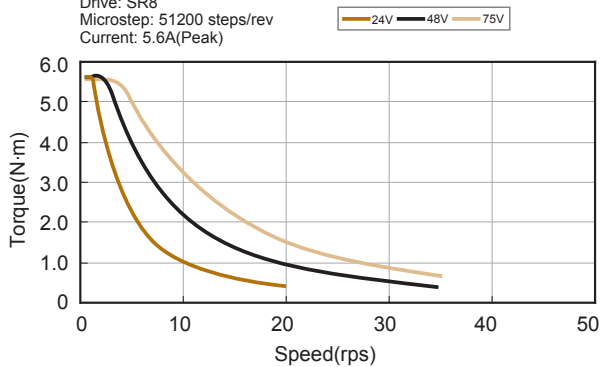

8 Contacting MOONS'



■ MOONS' Headquarter

168 Mingjia Road, Minhang District, Shanghai 201107,
P.R. China
Tel: +86 (0)21 52634688
Fax: +86 (0)21 52634098

■ MOONS' International Trading Company

4/F, Building 30, 69 Guiqing Road, Cao He Jin Hi-Tech
Park, Shanghai 200233, P.R. China
Tel: +86 (0)21 64952755
Fax: +86 (0)21 64951993

■ Domestic Offices

Shenzhen

Room 2209, 22/F, Kerry Center, 2008 Renminnan Road,
Luohu District, Shenzhen 518001, P.R. China
Tel: +86 (0)755 25472080
Fax: +86 (0)755 25472081

Beijing

Room 816, Tower B, China Electronics Plaza, 3 Danling
Street, Haidian District, Beijing 100080, P.R. China
Tel: +86 (0)10 58753312
Fax: +86 (0)10 58752279

Nanjing

Room 1101-1102, Building 2, New Town Development
Center, No.126 Tianyuan Road, Moling Street,
Jiangning District, Nanjing 211106, P.R. China
Tel: +86 (0)25 52785841
Fax: +86 (0)25 52785485

Qingdao

Room 1012, Zhuoyue Tower, No.16 Fengcheng Road,
Shibei District, Qingdao 26000, P.R. China
Tel: +86 (0)532 80969935
Fax: +86 (0)532 80919938

Wuhan

Room 3001, World Trade Tower, 686 Jiefang Avenue,
Jiangnan District, Wuhan 430022, P.R. China
Tel: +86 (0)27 85448742
Fax: +86 (0)27 85448355

Chengdu

Room 1917, Western Tower, 19, 4th Section of South People
Road, Wuhou District, Chengdu 610041, P.R. China
Tel: +86 (0)28 85268102
Fax: +86 (0)28 85268103

Xi'an

Room 1006, Tower D, Wangzuo International City,
1 Tangyan Road, Xi'an 710065, P.R. China
Tel: +86 (0)29 81870400
Fax: +86 (0)29 81870340

Ningbo

Room 309, Tower B, Taifu Plaza, 565 Jiangjia Road,
Jiangdong District, Ningbo, 315040, P.R. China
Tel: +86 (0)574 87052739
Fax: +86 (0)574 87052365

Guangzhou

Room 4006, Tower B, China Shine Plaza, 9 Linhe Xi Road,
Tianhe District, Guangzhou 510610, P.R. China
Tel: +86 (0)20 38010153
Fax: +86 (0)20 38103661

■ North America Company

MOONS' INDUSTRIES (AMERICA), INC.

1113 North Prospect Avenue, Itasca, IL 60143 USA
Tel: +1 630 8335940
Fax: +1 630 8335946

APPLIED MOTION PRODUCTS, INC.

404 Westridge Dr. Watsonville, CA 95076, USA
Tel: +1 831 7616555
Fax: +1 831 7616544

LIN ENGINEERING, INC.

16245 Vineyard Blvd., Morgan Hill, CA 95037
Tel: +1 408 9190200
Fax: +1 408 9190201

■ European Company

MOONS' INDUSTRIES (EUROPE) S.R.L.

Via Torri Bianche n.1 20871 Vimercate(MB) Italy
Tel: +39 039 6260521
Fax: +39 039 9631409

■ South-East company

MOONS' INDUSTRIES (SOUTH-EAST ASIA) PTE. LTD.

33 Ubi Avenue 3 #08-23 Vertex Singapore 408868
Tel: +65 66341198
Fax: +65 66341138

■ Japan Company

MOONS' INDUSTRIES JAPAN CO., LTD.

Room 601, 6F, Shin Yokohama Koushin Building,
2-12-1, Shin-Yokohama, Kohoku-ku, Yokohama,
Kanagawa, 222-0033, Japan
Tel: +81 (0)45 4755788
Fax: +81 (0)45 4755787